

(No Model.)

J. F. WHITNEY.
CENTERING DEVICE.

No. 272,995.

Patented Feb. 27, 1883.

Fig. 1.

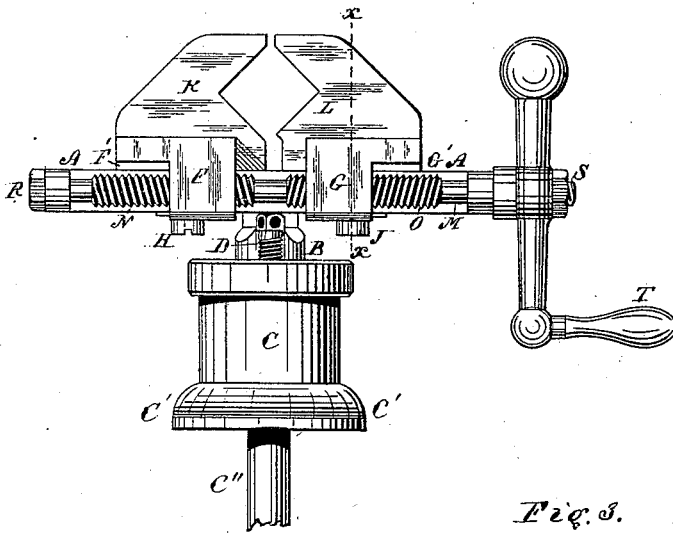

Fig. 3.

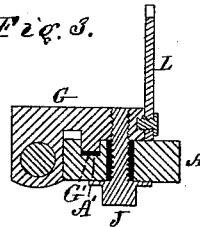
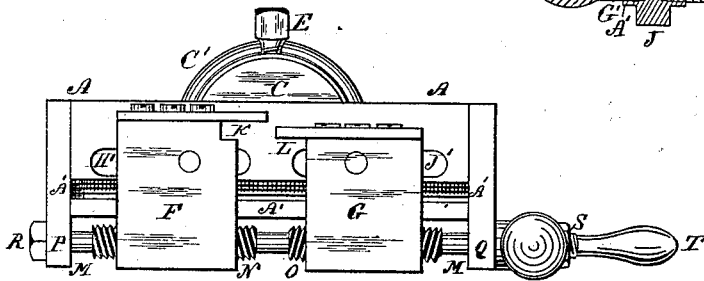

Fig. 2.



Witnesses:

Edwin T. Dimock,
Chas. L. Rudlett

Inventor,

James F. Whitney
by Thos. G. Ellis, Attorney

UNITED STATES PATENT OFFICE.

JAMES F. WHITNEY, OF HARTFORD, CONNECTICUT.

CENTERING DEVICE.

SPECIFICATION forming part of Letters Patent No. 272,995, dated February 27, 1883.

Application filed April 22, 1882. (No model.)

To all whom it may concern:

Be it known that I, JAMES F. WHITNEY, of Hartford, in the county of Hartford and State of Connecticut, have invented certain new and useful Improvements in Centering Devices; and I do hereby declare that the following is a full, clear, and exact description thereof, whereby a person skilled in the art can make and use the same, reference being had to the accompanying drawings, and to the letters of reference marked thereon.

Like letters in the figures indicate the same parts.

My improvement relates to a device to be attached to and used with a turning-lathe or other similar machine in which work is to be centered for turning, drilling, or any other operation requiring an accurate center to be fixed in the piece operated upon.

The object of my invention is to provide a mechanism which can be temporarily attached to the machine for this purpose, and which will center the work with greater precision and in an easier and more rapid manner than has heretofore been done.

In the accompanying drawings, illustrating my invention, Figure 1 is a front view of my improved centering device. Fig. 2 is a top view of the same. Fig. 3 is a cross-section on the line *xx* of Fig. 1.

A is a horizontal bar, which carries the working parts of my improved device. It has a vertical stem, B, which extends down into an opening in the block C, in which it fits and can move vertically.

D is an adjusting-screw, turning in the block C and bearing against the under side of the bar A. This screw is shown as provided with capstan-holes for turning.

E is a set-screw for clamping the stem B when it is set in the right position or adjustment.

F and G are two sliding blocks, moving back and forth upon the bar A. They are guided by the plain top surface of A and by the tongues F' G', which run in a groove, A', in the bar A. The blocks F and G are held down to the top surface of A by the bolts H and J, which pass through the elongated slots H' and J' and have heads bearing upon the under side of A.

K and L are the jaws which perform the centering. They are attached to the sliding blocks

F and G by screws, as shown in the drawings, or can form one piece with them. These jaws have a half-rectangle cut in each, the angles of which come opposite to each other, as shown in Fig. 1. The jaws are not opposite each other in the same line, but are so situated that they can pass one inside of the other, as shown in Fig. 2. This is for the purpose of centering small objects.

M is a shaft, upon which are the right and left screw-threads N and O, which pass through nuts or hollow threads in the blocks F and G for the purpose of moving the blocks simultaneously when the shaft M is turned by means of its handle T. The shaft M is held in bearings through the projections P and Q, which are attached to or form part of the horizontal bar A.

R and S are two nuts upon threads on the ends of the shaft M. They are for the purpose of adjusting the position of the screws N and O longitudinally, so that they shall move the two jaws in such a manner that the angles formed in the said jaws shall be equally distant from the exact center to which the work is to be set.

In order to apply my invention to a lathe, the bottom of the block C is furnished with a flange, C', so that the base fits into the groove in the usual slide-rest in the place of the tool-post and is set by a suitable mark. The exact height of the horizontal line joining the two angles of the jaws is then adjusted by means of the screw D, and the exact vertical line where the angles would meet by the nuts R S, which move the shaft M. The centering device can then be taken out or replaced at will.

For use in a vertical drill or other machine not provided with the groove for the flange on the base of the block C, a stem, C'', can be attached to C for insertion into a proper gage-hole in the frame of the machine.

The method of using my improvement in a lathe is to place one end of the bar or other object to be centered in the usual cup-center, and center the opposite end from the outside by means of my improved device, when a center-hole can be drilled in the usual manner. The ends of the object are then changed, and the opposite end centered in my improved device and the center hole drilled. Thus both ends are centered perfectly true for turning

or any other operation. When the work is placed in the lathe or other machine the jaws are separated by means of the right and left screws, turned by the handle T, and they are then brought together by a reverse movement of the handle and screws until the sides of the angular indentations of the jaws just touch the work or object to be centered. If the object is small, the jaws pass by each other until the object is included between the sides of the indentations.

What I claim as my invention is—

1. The combination of the bar A, with its stem B, the base C, the screw D, and the set-screw E, with the adjustable sliding blocks F and G, and the jaws K and L, substantially as described.

2. The sliding blocks F and G, provided with the overlapping jaws K and L, in combination with the bar A, the shaft M, provided with the right and left screws N and O, and the adjusting-nuts R S, substantially as described.

3. The combination of the bar A, the sliding blocks F and G, provided with jaws K and L, the adjustable right and left screw shaft M, the vertical adjusting-screw D, the stem B, and the base-block C, substantially as described.

JAMES F. WHITNEY.

Witnesses:

THEO. G. ELLIS,
EDWIN F. DIMOCK.